



REASONS TO CHOOSE KSH SERIES

The KSH series was designed to offer maximum options and possibilities for soft tactile switches. Based on C&K's customization, robustness and know how in tactile switches, KSH is able to match:

- An excellent tactile feeling confirmed both by a stable and high snap ratio and a very positive appreciation from our customers.
- A life expectancy at the highest market level combined with low variation of performances.
- A variety of haptic configurations, where actuation force is rated at 4 levels based on standard options. Extra variation of forces and travel is available upon request.
- Terminal options allow the customer to determine the best choice without limitations.
- A compatibility with our KSC series for having a full tactile switch system for a full choice of haptic without impact on mechanical integrations.

Manufactured with the highest automotive standards, KSH is the right solution for any car interior controls, where reliability, cost effectiveness, flexibility and accuracy need to be combined.

KSH • SOFT FEELING, HAPTIC, TACTILE, SWITCH

www.ck-components.com

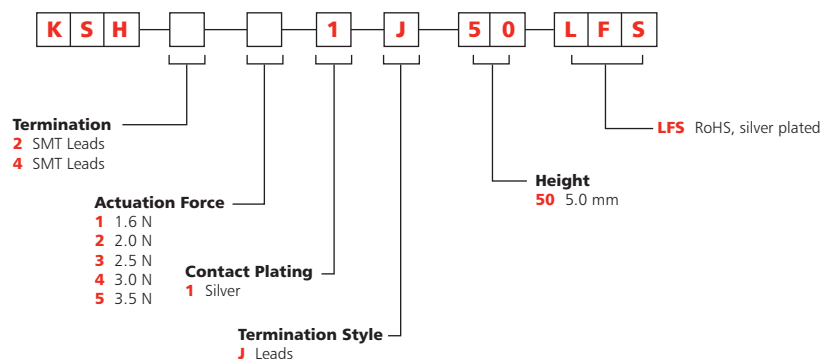
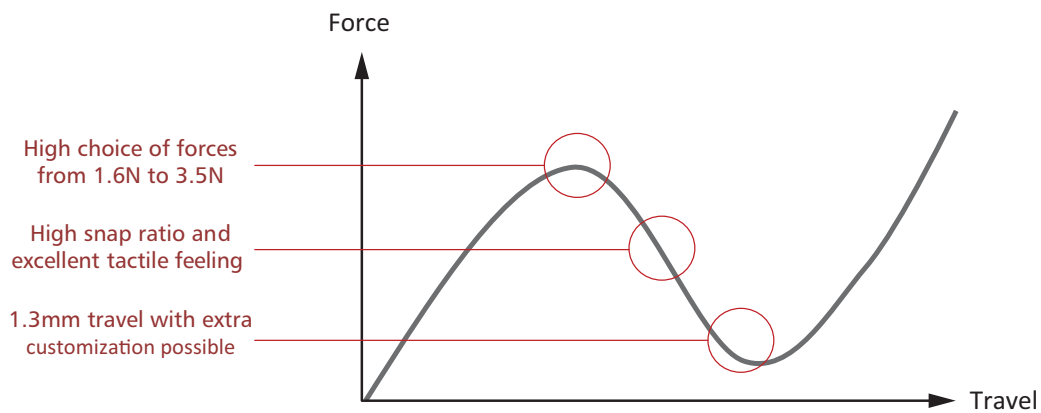
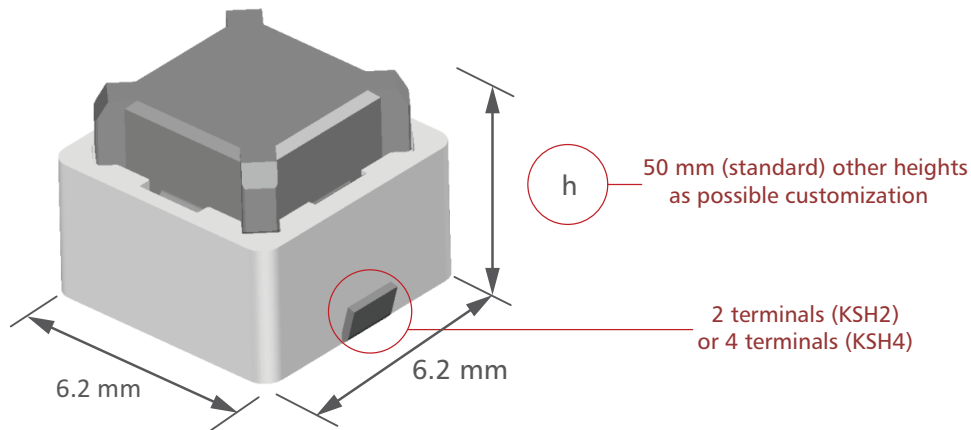

For more information please consult C&K KSH page at <http://www.ck-components.com/ksh/tactile,86426,en.html>

AMERICAS

Tel: +1.617.969.3700

FRANCE

Southern and Western Europe

Tel: +33.1.60.24.51.51

GERMANY

Central and Eastern Europe & Nordic

Tel: +49.30.814.539.250

HONG KONG

Tel: +852.3713.5288

SHANGHAI

Tel: +86.21.5413.0137

